

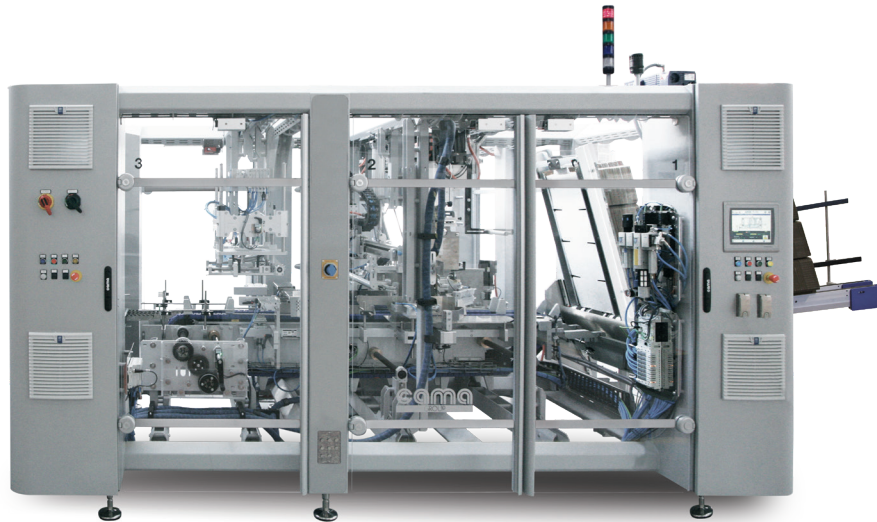

# WRAP AROUND DISPLAY BOX



CAMA GROUP IS A LEADING SUPPLIER OF ADVANCED TECHNOLOGY SECONDARY PACKAGING SYSTEMS, CONTINUOUSLY INVESTING IN INNOVATIVE SOLUTIONS. WHAT MAKES CAMA UNIQUE IN THE FIELD OF PACKAGING IS A “GLOBAL CONSULTING APPROACH” TO EACH CUSTOMER’S PACKAGING AUTOMATION REQUESTS.

## WRAP AROUND AND DISPLAY BOX

Cama innovative solutions for RRP (Retail Ready Packaging) provide a wide range of successful machines developed over the years. Cama FW case packers are capable of packing a variety of products into onepiece wrap-around or two-piece display cases for retail-ready packaging solutions. The Cama FW Case Packers are capable of packing a variety of products into a one-piece wrap-around or two-piece display cases for Shelf Ready packaging solutions.

## RANGE OF MACHINES

**FW 746** Electronic Mini Wrap-around case packers for packing products such as bags, boxes, cups, flow-wraps and rigid containers into wrap-around cases.

**FW 748** By means of suitable loading systems, products can be positioned into the case flat, on edge or standing up on one or multiple layers.

**FW 749-751** Electronic Wrap-around case packers for packing products such as bags, boxes, cups, flow-wraps and rigid containers into a 2-piece (tray and lid) display box.

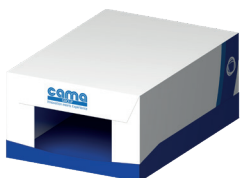

*TRAY AND LID*

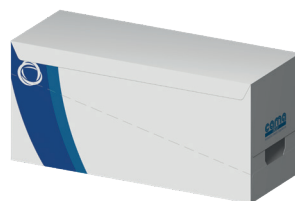

*DISPLAY BOX*



*WRAP AROUND*

## SPECIAL FEATURES OF MACHINE

- METAL FRAME OR STAINLESS STEEL
- HIGH SPEED
- VARIOUS TYPE OF PRIMARY PRODUCT (POUCHES, FLOWPACK, THERMOFORMED ETC.)
- TYPE INDUSTRY
- LEFT AND RIGHT HAND

## BREAK THROUGH GENERATION

- NO HOLLOW BODY
- MODULAR FRAME DESIGN
- NO RETENTION
- ENERGY SAVING
- ERGONOMICS
- SAFE EASY ENTRY
- SEMI AUTOMATIC CHANGE OVER

## INDUSTRY

- FOOD
- BEVERAGES
- PERSONAL, HOME & HEALTH CARE
- PET FOOD

**MACHINE LAYOUT**

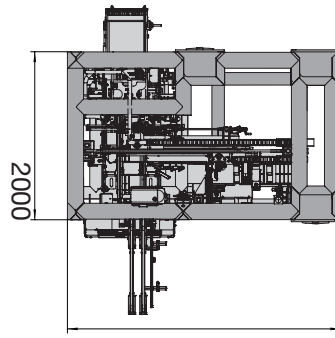

2000

3300

FW746

---

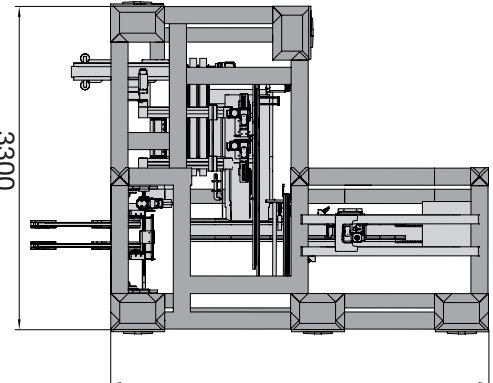

3300

5000

FW748

---

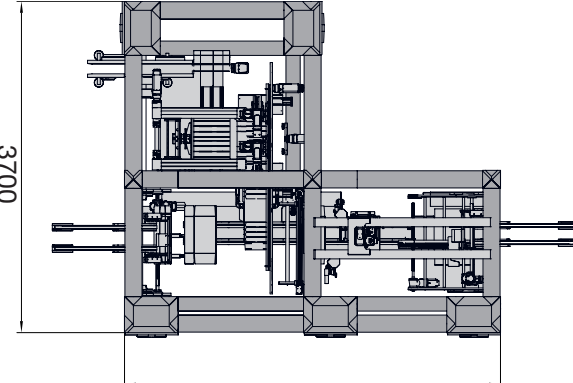

3700

5000

FW749

FW 746		SIZES (MM)		
MIN		A	B	C
		90	90	135
MAX		A	B	C
		230	350	430
		SPEED (CPM)		
		MIN	MAX	
		-	32	
FW 748		SIZES (MM)		
MIN		A	B	C
		100	100	145
MAX		A	B	C
		400	350	600
		SPEED (CPM)		
		MIN	MAX	
		-	32	
FW 751		SIZES (MM)		
MIN		A	B	C
		100	100	145
MAX		A	B	C
		400	350	600
		SPEED (CPM)		
		MIN	MAX	
		-	17-25	