

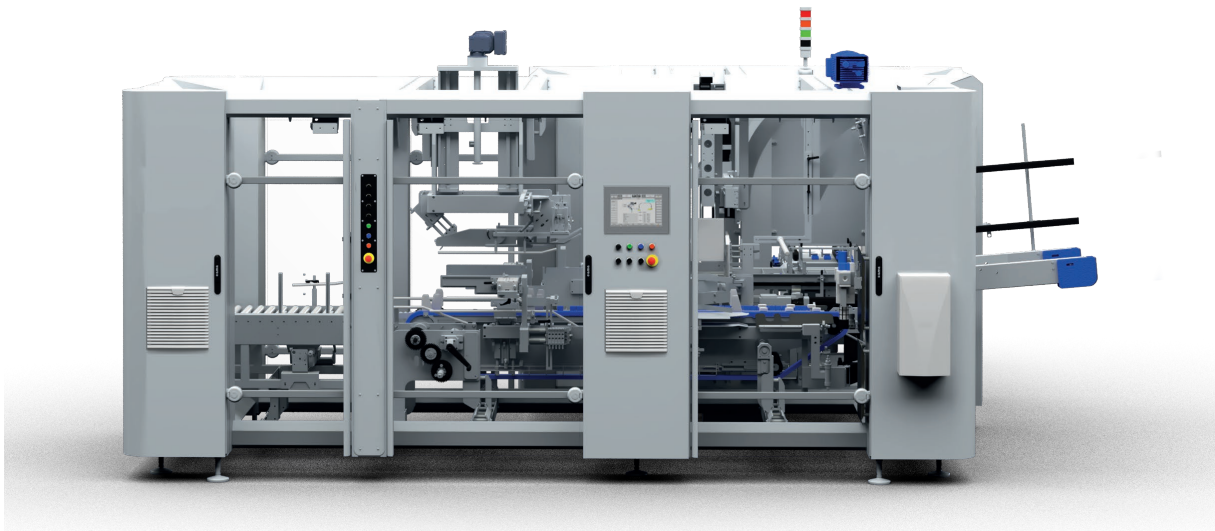

HORIZONTAL RSC CASE PACKER

cama
GROUP
Innovation meets Experience



CAMA GROUP IS A LEADING SUPPLIER OF ADVANCED TECHNOLOGY SECONDARY PACKAGING SYSTEMS, CONTINUOUSLY INVESTING IN INNOVATIVE SOLUTIONS. WHAT MAKES CAMA UNIQUE IN THE FIELD OF PACKAGING IS A “GLOBAL CONSULTING APPROACH” TO EACH CUSTOMER’S PACKAGING AUTOMATION REQUESTS.

RSC CASE PACKER

Cama’s Case Packers IN series provide flexibility, trouble-free running and high productivity IN Electronic RSC case packers born to pack products such as bags, boxes, cups, flow-wraps and rigid containers into RSC cases. By utilizing suitable loading systems, products can be positioned into the case flat, on edge or standing up on one or multiple layers.

RANGE OF MACHINES

IN 205-216-218 Side load RSC case packing system that erects, loads and closes each case with tape or glue. Product orientation in the case is manipulated into the layer forming conveyor to allow for multiple configurations to be loaded.

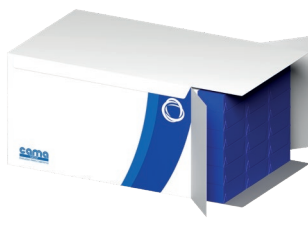

GLUE

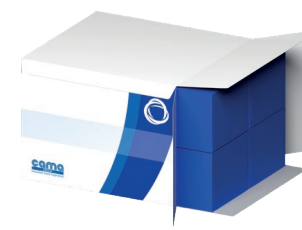

TAPE

SPECIAL FEATURES OF MACHINE

- METAL FRAME / STAINLESS STEEL
- HIGH SPEED, LOW SPEED
- VARIOUS TYPE OF PRIMARY PRODUCT (POUCHES, FLOWPACK, THERMOFORMED ETC.)
- VARIOUS LOADING UNITS

BREAK THROUGH GENERATION

- NO HOLLOW BODY
- MODULAR FRAME DESIGN
- NO RETENTION
- ENERGY SAVING
- ERGONOMICS
- SAFE EASY ENTRY
- SEMI AUTOMATIC CHANGE OVER

INDUSTRY

- BAKERY & BISCUITS
- CONFECTIONERY
- DAIRY & ICE CREAM
- COFFEE & TEA
- PERSONAL, HOME & HEALTH CARE
- PET FOOD

MACHINE LAYOUT

IN205

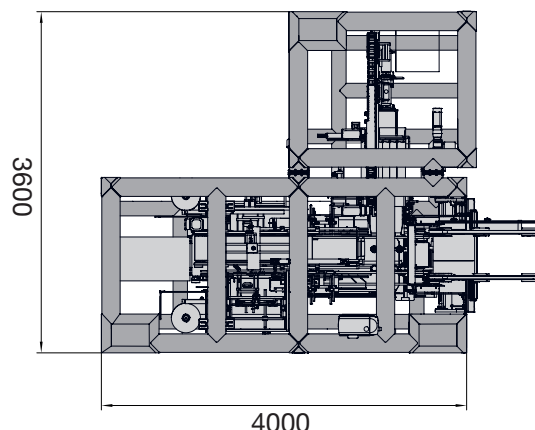

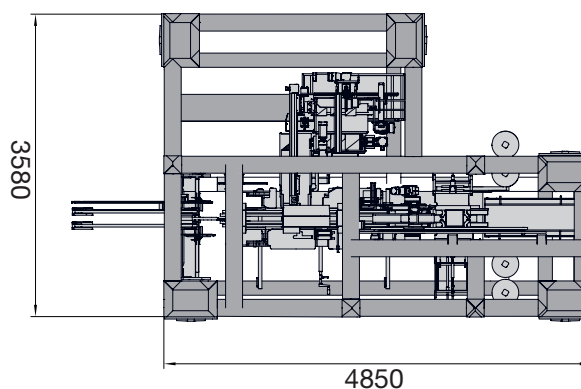

IN216

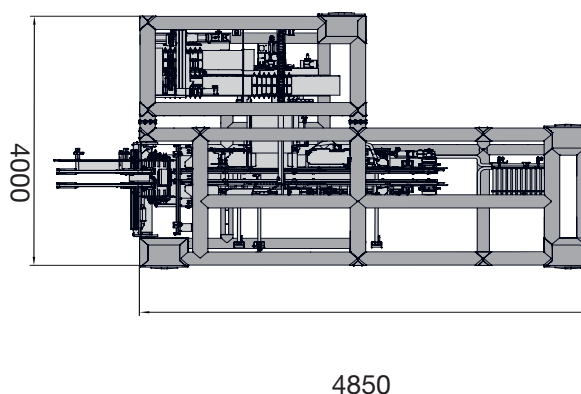

IN218

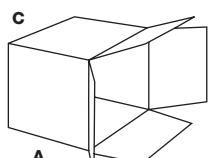
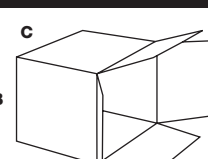

IN 205		SIZES (MM)		
		A	B	C
	MIN	250	170	150
	MAX	600	400	400
		SPEED (CPM)		
		GLUE	TAPE	
		9	9	
IN 216		SIZES (MM)		
	MIN	250	150	170
	MAX	600	400	400
		SPEED (CPM)		
		GLUE	TAPE	
		25	20	
IN 218		SIZES (MM)		
	MIN	250	150	170
	MAX	600	400	600
		SPEED (CPM)		
		GLUE	TAPE	
		16	16	