

CAMA GROUP IS A LEADING SUPPLIER OF ADVANCED TECHNOLOGY SECONDARY PACKAGING SYSTEMS, CONTINUOUSLY INVESTING IN INNOVATIVE SOLUTIONS. WHAT MAKES CAMA UNIQUE IN THE FIELD OF PACKAGING IS A “GLOBAL CONSULTING APPROACH” TO EACH CUSTOMER’S PACKAGING AUTOMATION REQUESTS.

CLOSING BOX

Fully automatic carton closing machine for one- or three-flaps boxes are available in linear or 90° angle versions, with hot melt or tuck closure. The machine is available with single or multi closing heads, according to your precise packaging requirements.

RANGE OF MACHINES

CD 58-59 Intermittent 90° (CD58) and continuous motion inline (CD59) box Closing Machines. Hot melt electronic closing machines for boxes with 1 or 3-flap lids. Perfect alignment of the lid, rotary wheel available for high speed and smooth 90° transfer. Compact machine, flexible frame approach, hygienic machine design, easy entry and access.



ONE FLAP



THREE FLAPS

SPECIAL FEATURES OF MACHINE

- METAL FRAME OR STAINLESS STEEL
- HIGH SPEED
- VARIOUS TYPE OF PRIMARY PRODUCT (POUCHES, FLOWPACK, THERMOFORMED ETC.)
- TYPE INDUSTRY
- LEFT AND RIGHT HAND

BREAK THROUGH GENERATION

- NO HOLLOW BODY
- MODULAR FRAME DESIGN
- NO RETENTION
- ENERGY SAVING
- ERGONOMICS
- SAFE EASY ENTRY
- SEMI AUTOMATIC CHANGE OVER

INDUSTRY

- FOOD
- BEVERAGES
- PERSONAL, HOME & HEALTH CARE
- PET FOOD

MACHINE LAYOUT

CD 58

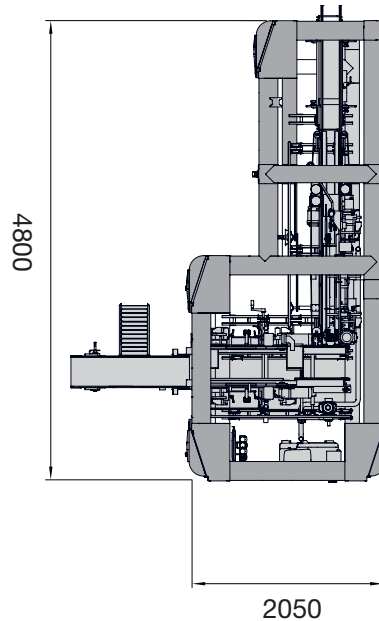

CD 59

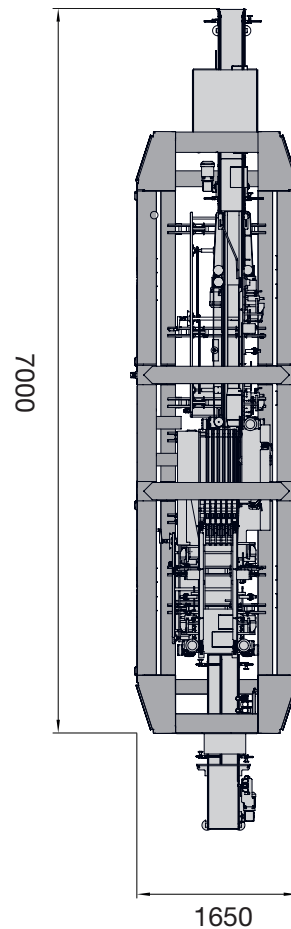

CD 58		SIZES (MM)		
		A	B	C
	MIN	130	80	30
	MAX	400	290	200
		SPEED (CPM)		
		MIN	MAX	
		-	120	
CD 59		SIZES (MM)		
		A	B	C
	MIN	130	100	30
	MAX	400	270	200
		SPEED (CPM)		
		MIN	MAX	
		-	120	
CD 59S		SIZES (MM)		
		A	B	C
	MIN	135	100	30
	MAX	400	270	200
		SPEED (CPM)		
		MIN	MAX	
		-	150	